

GYA6000LB 轮式沥青摊铺机



TYRE ASPHALT PAVER



主要性能 FEATURE OF MACHINE

- 配置康明斯电喷发动机，功率强劲，可靠性高，能够胜任恶劣的摊铺工况。
- 配置复合式散热器，通过集中智能散热，分仓导流，可保证整机在 50℃高温下长时间工作。
- 螺旋布料系统和刮板供料系统均为独立驱动，关键液压元件如泵、马达、接头等原装进口匹配合理，能够适应任何稳定土及沥青混合料的输送、摊铺。
- 全轮驱动机型，提供更大的牵引力，满足重载及较松软路基下的作业工况。
- 具有专利保护的独特的双重制动保护装置，能够在主传动系统制动失灵的情况下，安全可靠的实现整车制动。
- 整机外形简洁、大方、美观，维修保养方便。
- Many uses of tyre asphalt paver, fast conversion of job site, good flexibility and high performance.
- Adopting Cummins electronic-injection with strong power and high reliability, suitable for wicked working conditions
- Compound radiator, centralized intelligent heat dissipation, independent diversion, constant services under 50 °C.
- Independent drives for helical material auger system and conveyor system, original imported key hydraulic components, such as pump, motor, joint, reasonable matching, ensure feeding and paving of stabilized soil and asphalt material.

- full-drives (6x6) asphalt paver, more powerful traction.
- Particular double-brake protection device with patent, safe and reliable entire brake while main transmission brake system out of control.
- Simple, natural and specious appearance, convenience for maintain and repair.

(国机) 天津工程机械研究院有限公司
(SINOMACH) Tianjin Research Institute of Construction Machinery Co., Ltd



主要尺寸 Main Dimension

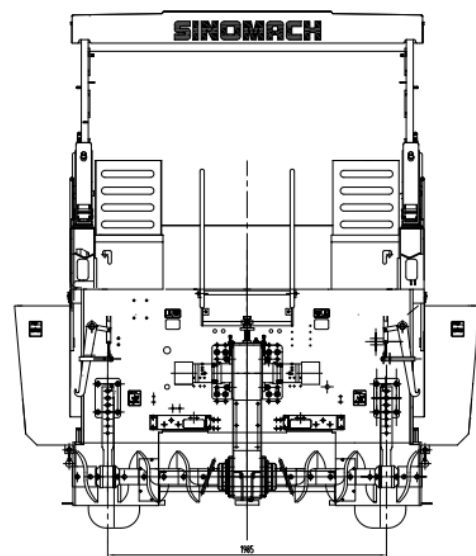
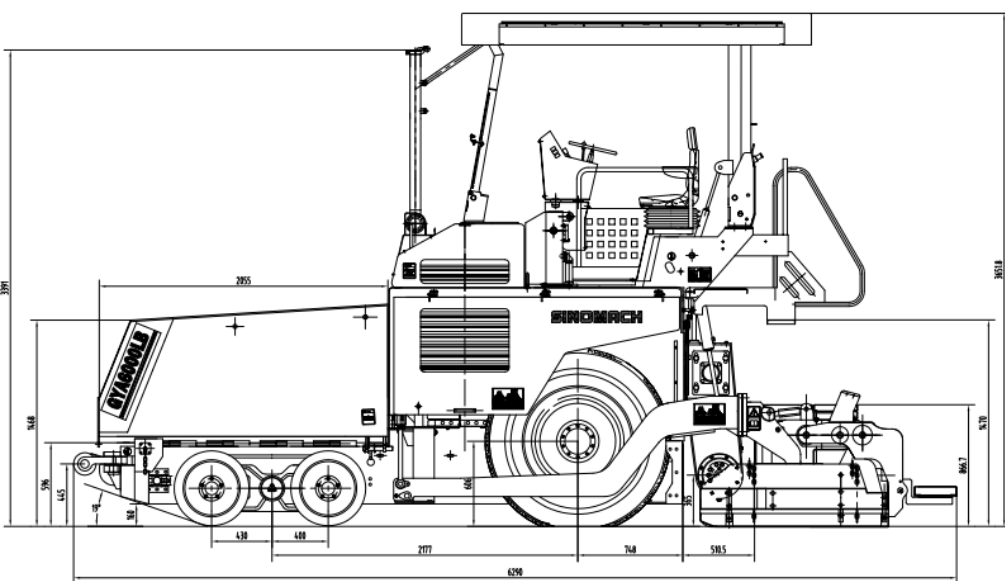

主要技术参数 Main Technical Parameters

| 项目/item | 单位/unit | GYA6000LB |
|-------------------------------------|----------|------------------|
| 行走方式/travel model | 驱动/drive | 全轮驱动/full drives |
| 基本摊铺宽度/Basic paving width | m | 2.5 |
| 最大摊铺宽度/Max. paving width | m | 6.0 |
| 最大摊铺厚度/Max. paving thickness | mm | 200 |
| 摊铺工作速度/Working speed | m/min | 0-15 |
| 行驶速度/Running speed | km/h | 0-15 |
| 理论生产率/Theoretical productivity | t/h | 400 |
| 料斗容量/Hopper capacity | t | 13 |
| 爬坡能力/Grade.ability | % | ≥20 |
| 平整度误差(纵波)/Leveling tolerance (wave) | mm/3m | 1.5 |
| 横波误差/Transverse Wave Error | % | ±0.02 |
| 拱度调节范围/Arch degree adjusting range | % | -1~+3 |
| 生产厂商/manufacturer | / | 康明斯 Cummins |
| 型号/Model | / | QSB3.9-C125 |
| 额定功率/Rated power | kW | 93 |

| | | |
|------------------------|-----|---------------------|
| 额定转速/Rated speed | rpm | 2200 |
| 排放标准 Emission standard | / | 国 3/Stage III |
| 压实方式/Compaction type | / | 振捣/tamper |
| 加热方式/Heating type | / | 柴油加热/Diesel |
| 整机尺寸/Machine dimension | mm | 6290x2690x3570/3000 |
| 总质量/ Total mass | t | 17 (1±5%) |

因产品改进技术参数如果变动恕不通知

With the improvement of product, the design or specification are subject to change without notice

地址：天津市北辰科技园区华实道 91 号

ADD: N°91 HuashiRoad,Beichen Sceinece & Technology park,Tianjin

电话：022-26899319

Tel:+86-22-26899319

网址：Http: //www.cm518.com

Website:Http://www.cm518.com

GYA6000LB 主要配置表/Main components

| 序号 N° | 名称 Commodity | 品牌 Brand | 国别 Country | 工作参数 Parameters | 整机用量 QTY |
|----------|----------------------|------------------|---------------|--------------------|-------------|
| 1 | 发动机 Engine | 东风康明斯 Cummins | 中国 China | 93kW/2200rpm | 1 个 |
| 2 | 分动箱 Transfer Case | 秦川机械 Qinchuan | 中国 China | 120kW/2200rpm | 1 个 |
| 3 | 行走泵 | 萨奥 | 美国 USA | 0~55ml/r、35MPa | 1 个 |

| | | | | | |
|----|------------------------------|--------------------|---------------|---------------------|-----|
| | Travel Pump | SAUER | | | |
| 4 | 行走马达 Travel Motor | 贵州力源 LiYuan | 中国 China | 80ml/r、35MPa | 1 个 |
| 5 | 后桥减速机 Reduction-gear | 邦飞利 Bonfiglioli | 意大利 Italy | I=5.33/12000Nm | 2 个 |
| 6 | 后桥主传动 Main drive | 分宜桥厂 FenYI | 中国 China | | 1 个 |
| 7 | 变速箱 Transmission | 秦川机械 QinChuan | 中国 China | 双速 Double-speeds | 1 个 |
| 8 | 驻车制动器 Parking Brake | 邦飞利 Bonfiglioli | 意大利 Italy | 2MPa | 1 个 |
| 9 | 行车制动器 Travel Brake | 日照金丰 RiZhao | 中国 China | | 2 个 |
| 10 | 后轮轮胎 Rear Tyres | 国际轮胎 | 中国 | | 2 个 |
| 11 | 螺旋泵 Screw Pump | 萨奥 SAUER | 美国 USA | 0-45ml/r、16MPa | 1 个 |
| 12 | 螺旋马达 Screw Motor | 伊顿 YiDun | 中国 China | 490ml/r、16MPa | 2 个 |
| 13 | 螺旋控制阀 Screw control valve | DANFOSS | 美国 USA | | 1 个 |
| 14 | 刮板泵 Scraper Blade Pump | 派克 Parker | 中国 China | 10+10ml/r、16MPa | 2 个 |
| 15 | 刮板马达 Scraper Motor | 伊顿 YiDun | 中国 China | 625ml/r、16MPa | 2 个 |
| 16 | 振捣泵 Tampor Pump | 派克 Parker | 中国 China | 10ml/r、16MPa | 1 个 |
| 17 | 振捣马达 Tampor Motor | BUCHER | 德国 Germany | 15+15ml/r、16MPa | 1 个 |
| 18 | 振动马达 | 邦地奥里 Bondioli & | 意大利 Italy | 17ml/r、16MPa | 2 个 |

| | | | | | |
|----|---------------------------------------|------------------------------|---------------|---|-----|
| | Vibration Motor | Pavesi | | | |
| 19 | 振捣调速阀 Tampor speed Vavle | BUCHER | 德国 Germany | | 1 个 |
| 20 | 振动泵 Vibration Pump | 派克特精 Parker | 中国 China | 10ml/r、16MPa | 1 个 |
| 21 | 振动马达 Vibration Motor | 邦地奥里 Bondioli & Pavesi | 意大利 Italy | 6ml/r、16MPa | 4 个 |
| 22 | 前驱马达 Drive motor of front wheel | 波克兰 Poclain | 法国 France | 820ml/r、25MPa | 4 个 |
| 23 | 辅助泵 Auxiliary pump | 派克特精 Parker | 中国 China | 12ml/r、16MPa | 1 个 |
| 24 | 转向泵 Steering Pump | 派克特精 Parker | 中国 China | 5ml/r、16MPa | 1 个 |
| 25 | 加热系统 Heating System | 常州通联 Tonly | 中国 China | 柴油加热 Diesel Heating | 1 套 |
| 26 | 国产调平仪 Leveling Instrument | 通联 Tonly | 中国 | TPY-GC-24V | 1 套 |
| 27 | 螺旋传感器 Screw sensor | 通联 Tonly | 中国 China | TYPE 13A | 2 个 |
| 28 | 刮板控制器 Scraper Blade Controller | 公司产品 | 中国 China | | 2 个 |
| 29 | 仪表 Instrument Ass' y | 科蒂斯 VDO | 美国 USA | | 1 套 |
| 30 | 伸缩熨平板 Screed | 公司产品 | 中国 | 单振捣液压伸缩 Single-Vibration extensive Screed | 1 套 |